



BRUGG

Lifting



Elevator ropes

General Catalogue



BRUGG

Lifting



We are Brugg Lifting	4
Our Elevator Ropes	14
BRURope – Coated	18
BRUbelt	20
BRURope – Steel Core	24
BRURope – Mixed Core	26
BRURope – Fiber Core	27
BRURope – Governor	28
BRURope – Compensation	29
Our Accessories	30
Technical information	46
Contacts & Support	59

The sky
is not the limit,
it's the goal.



**At BRUGG Lifting,
we help customers
become leaders
in lifting technology.**



Our mission is to empower you to take elevator design to new heights. With premium elevator ropes and tailored support, we facilitate the design process, streamline your supply chain and help reduce risk. Our experts are there every step of the way to make innovation easier, from strategic product development to global delivery, installation training to long-term customer service. Together, we can think bigger, aim higher and push the boundaries of what's possible in lifting.



800
700
600
500
400
300
200
100
0

Together,
we can
reach
new
heights.

828 m / 2.717ft Burj Khalifa - Dubai - UAE

553 m / 1.814ft CN Tower - Toronto - CDN
541 m / 1.776ft One World Trade Center - New York - USA

468 m / 1.535ft Oriental Pearl - Shanghai - CN
452 m / 1.483ft Petronas Tower - Kuala Lumpur - MAL
449 m / 1.473ft Empire State Building - New York - USA
448 m / 1.470ft Federation Tower - Moscow - RUS

412 m / 1.352ft IFC - Hongkong - CN

351 m / 1.033ft Stratosphere Tower - Las Vegas - USA

310 m / 1.017ft Telekom HQ - Kuala Lumpur - MAL
297 m / 974ft Comcast Center - Philadelphia - USA
288 m / 945ft Plaza 66 - Shanghai - CN
284 m / 932ft Tomorrow Square - Shanghai - CN
280 m / 919ft Foreign Ministry - Moscow - RUS
233 m / 764ft Harbourfront - Hong Kong - CN
225 m / 738ft Torre Mayor - Mexico City - MEX
218 m / 715ft Shang Mao Real Estate - Nanjing - CN
213 m / 699ft Shangria-La - Hong Kong - CN

177 m / 581ft Millenium Tower - Vienna - A
169 m / 554ft Shalom Centre - Tel Aviv - IL
153 m / 502ft Fairmont (Park Plaza) - Dubai - UAE
138 m / 453ft Twintower - Vienna - A
135 m / 443ft Nürnberger Versicherung - Nuremberg - DE
130 m / 427ft Castor - Frankfurt - DE
105 m / 344ft Messeturm - Basel - CH
96 m / 226ft Platinum Tower - Tel Aviv - IL



BRUGG Lifting is a global manufacturer of elevator ropes, architectural ropes, wire ropes and lashing and lifting gear. But we're not just a product supplier; we're a partner in innovative elevator design.

Our global team supports your projects from start to finish to take the guesswork out of product development. With premium ropes, collaborative relationships and personalized support, we help strengthen your in-house expertise and capacity for innovation, empowering you to create safer, more modern elevators.

Together, we're reaching new heights in elevator design so you can become a leader in the lifting industry.



With more than 125 years of group history, three production sites and multiple distribution companies in Europe, North America and Asia, and a range of innovative digital services, the company is a partner to elevator manufacturers around the world.

Beating gravity
for more than
120 years



Partnership
at every
eve



Systems approach



We offer a wide range of elevator ropes, coated technologies, accessories and tools to meet your precise requirements. We can supply complete packages or individual parts depending on your project.

Project facilitation



We make product development easier by facilitating communication between different departments and locations. We'll work with R&D, Engineering, Sales, etc. to ensure our solution fits your strategic needs.

Customized solutions



Pushing the boundaries of lifting can mean creating something completely new. As a partner in innovative elevator design, we work with you to co-create custom products or services aligned with your overall strategy.

Continuous support



With multilingual experts around the world, we offer free installation training, on-site visits and troubleshooting to extend the lifespan of your elevators, improve system performance and prevent new issues from arising.

Guaranteed safety



Our premium ropes are manufactured to the highest international standards for maximum reliability and quality, helping extend the lifespan of your elevators. We are certified to ISO9001:2015 and ISO 14001:2015 standards.

Availability and speed



With a global production and distribution network, we deliver what you need, when and where you need it. When time is critical, our express service provides materials immediately and ships them by courier around the world.





Our Elevator Ropes



Take your elevators to the next level with our premium rope technology









As system supplier, we have the corresponding end terminations, buffer systems and accessories for all elevator ropes in our product range.

Most items are available from inventory, allowing short delivery times and seamless logistics.

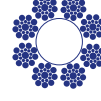
We specialize in the development and manufacture of threaded swaged end fittings and can also provide customized end terminations.

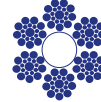
We help take the risk out of innovation with premium products that are trusted worldwide for their quality and performance. We start by sourcing raw materials exclusively from select suppliers that meet our high standards. Our modern production technologies and, above all, the skill and experience of our global teams ensure consistent quality, every time. We control our manufacturing processes and production lines with the latest measuring and monitoring techniques. Meanwhile, our in-house test facility allows us to continuously validate the quality of our products with fatigue tests and property analysis using statistical evaluation.

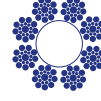
			Elastic elongation	Permanent elongation	Lifting height
	CTP® Full Steel Core Rope with TPU Coating Separate Lay (IWRC) 6 strands		0,129 %	0,15 %	≤ 75 m ≤ 250 ft
	BRUbelt 	Flat, high strength belts for materials handling, lifting equipment and drives			
	HRS Full Steel Core Rope Parallel Lay (PWRC) 9 Strands		0,070 %	0,090 %	≤ 425 m ≤ 1400 ft
	SCX9 Full Steel Core Rope Separate Lay (IWRC) 9 Strands		0,083 %	0,100 %	≤ 325 m ≤ 1000 ft
	TSR Full Steel Core Rope Separate Lay (IWRC) 6 Strands. Zinc-Plated		0,102 %	0,120 %	≤ 75 m ≤ 250 ft
	DP9 Mixed Core Rope Parallel Lay (PWRC) 9 Strands		0,091 %	0,200 %	≤ 250 m ≤ 800 ft
	MCX9 Mixed Core Rope Separate Lay (IWRC) 9 Strands		0,093 %	0,200 %	≤ 200 m ≤ 650 ft

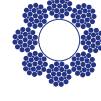
			Elastic elongation	Permanent elongation	Lifting height
	8X19 Fiber Core Rope NFC (Sisal) 8 Strands		0,101 %	0,290 %	≤ 75 m ≤ 250 ft
		6X19 Wire Rope with Polypropylene Core 6 Strands. Seale			
	8X19 Wire Rope with Polypropylene Core 8 Strands. Seale				
	8X19 Wire Rope with Polypropylene Core 8 Strands. Seale				
	8X25 Wire Rope with Polypropylene Core 8 Strands. Filler				

i-Line & Color Coding

Correctly installed hoist ropes increase the service life and safety of the elevator while improving riding comfort and reducing downtime. Regardless of the construction or the producer, every hoist rope is susceptible to untwisting during the installation. With the help of the i-LINE, which is applied to BRUGG Lifting hoist ropes during production, untwisted hoist ropes can be located, detected and corrected quickly and easily.

BRUrope Color Code

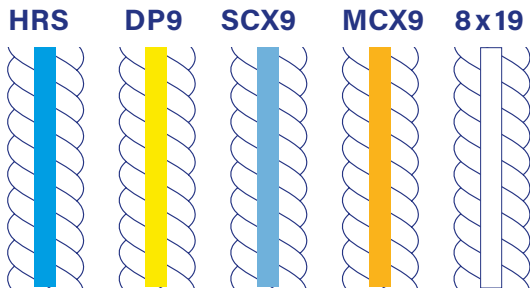

Advantages of the i-LINE

- 👍 simple and correct installation
- 👍 safe installation aid
- 👍 optimizes product performance
- 👍 color-coded for the identification of the rope type

Designation and classification of wire ropes (EN 12385-2 formerly ISO 17893)

Abbreviated designations

A
B
C
D
E
F
G
 12 8 x19S-NFC 1370/1770 U sZ

Example

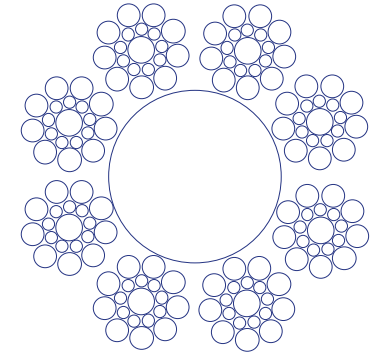

A Rope nominal Diameter in mm
(See corresponding table for each)

B Rope Construction

- C Construction**
- single lay strand
example for strand construction: 7 d.h. (1-6)
 - S seale parallel lay
example for strand construction: 19S d.h. (1-9-9)
 - W warrington parallel lay
example for strand construction: 19W d.h. (1-6-6+6)
 - F filler parallel lay
example for strand construction: 21F d.h. (1-5-5F-10)
25F d.h. (1-6-6F-12)
 - WS combined (Warrington Seale) parallel lay
example for strand construction: 31WS d.h. (1-6-6+6-12)

- D Construction of Core**
- Single layer rope with fibre core FC
 - NFC natural fibre core
 - SFC synthetic fiber core
 - Single layer rope with steel core WC
 - WSC wire strand core
 - IWRC independant wire rope core

- Rope with parallel lay
- PWRC parallel wire rope centre

E Nominal Tensile Grade of Wires in N/mm²

- F Surface Finish of Wires**
- U bright
 - B zinc coated (class B)

- G Direction of Lay**
- z right lay (strand)
 - s left lay (strand)
 - Z right lay (rope)
 - S left lay (rope)
 - sZ (RRL) right regular lay
 - zS (LRL) left regular lay
 - zZ (RLL) right lang lay
 - sS (LLL) left lang lay

Elastic Elongation in %

Elastic elongation is the elongation that occurs when a rope is loaded. When the load is removed, the rope is restored to its initial state.

Example: With a DP9 rope, a load of 5% of the minimum breaking force results in an elastic elongation of ca. 0.091% of the length of the rope (with a length of 100 m, this is equivalent to 91 mm).

Elevator ropes from BRUGG Lifting are especially characterized by a very low elastic elongation.

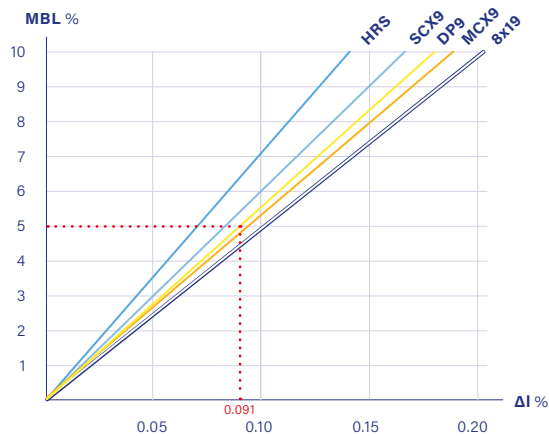

Permanent Elongation in %

Permanent elongation refers to the elongation at which a rope settles as a result of operation. This elongation is expected to occur at about 2% of the estimated rope service life.

The graphic compares the permanent elongation of the different types of suspension ropes.

Elevator ropes from BRUGG Lifting are especially characterized by a very low permanent elongation.

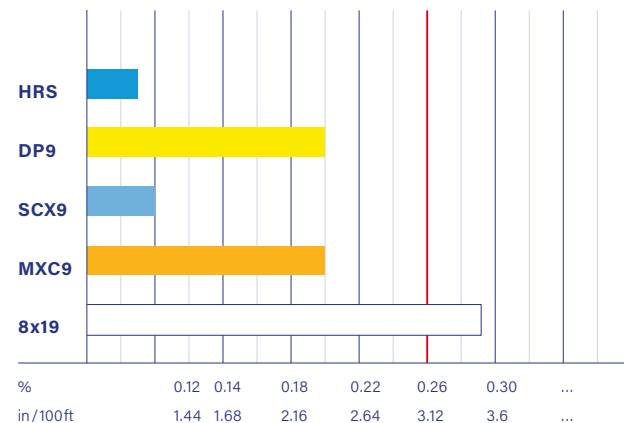

Minimum Breaking Load in %

MBL represents the minimum load that can be applied to a rope before it breaks.

The graphic compares the minimum breaking load of the different types of suspension ropes.

Reference: 100% = 8x19 suspension rope with natural fiber core.

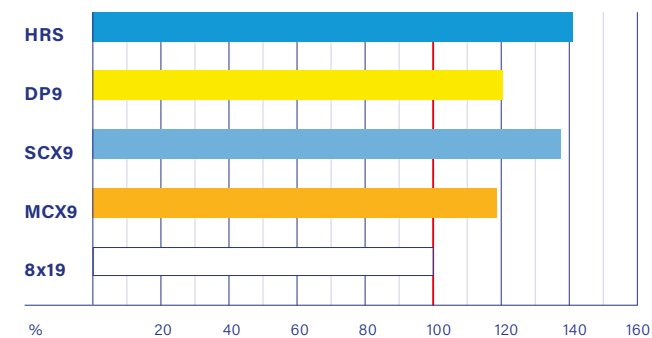

CTP[®]

**Full Steel Core Rope with TPU Coating
Separate Lay (IWRC)
6 strands, Brass Plated**

For highest demands on elongation, riding comfort and service life

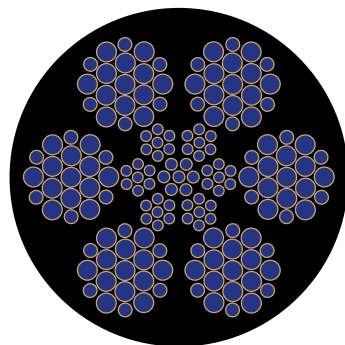

item number	rope ø	breaking load min.	weight	construction
	mm	kN	kg/100m	
10982	6.5	23.60	11.0	6x19S-IWRC
73106	8.1	33.56	17.9	6x19W-IWRC
78991	10	52.00	29.1	6x19W-IWRC

*There is no limitation on lifting heights however experience to date is limited to installations below 75m. Certified and in Production. Available in Stock length and in cut lengths.



Elastic elongation	Permanent elongation	Lifting height*
0,129%	0,150%	≤ 75 m
		≤ 250 ft



A world first, CTP® unites technological innovation for the highest demands. This high-end rope is unbeatable in terms of function and efficiency.

Reduce your total cost by up to 40%.

A smaller rope diameter and a smaller drive allow for a reduction of capital and operating cost.

Reduce your maintenance cost by up to 100%.

CTP® is a self-contained system that eliminates the need for lubrication and minimizes maintenance.

Improve travel comfort.

The polymer coating eliminates or strongly absorbs vibrations, which significantly contributes to a smooth running.

Increase the service life.

As there is negligible wear between the traction sheave and the rope, the frequency of rope replacement is much reduced.

Specified Groove Diagram for CTP® 6.5 mm

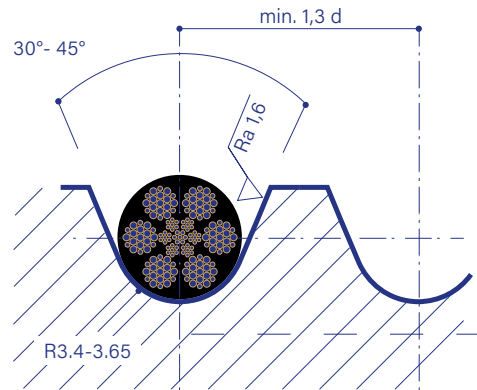

Specified Groove Diagram for CTP® 8.1 mm

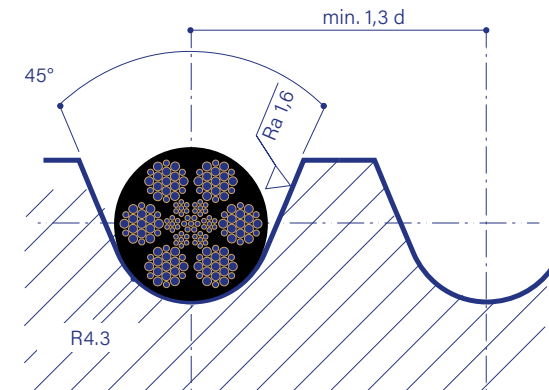

Specified Groove Diagram for CTP® 10 mm

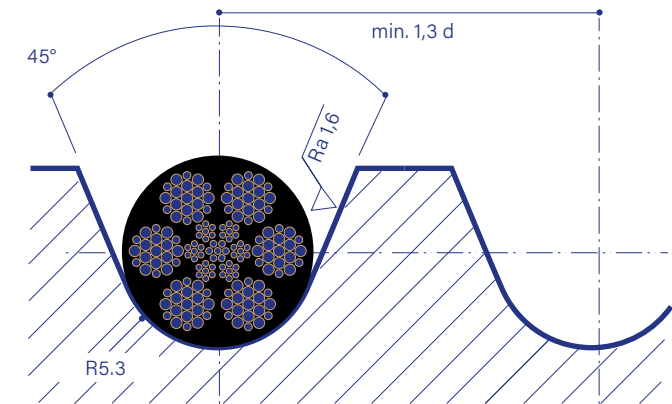

Main data of traction sheave / deflection

item number	rope ø	steel rope ø	friction coefficient	rope speed max.	sheave dia.	traction sheave material	groove shape	deflector sheave material
	mm	mm		m/s	mm		semicircular R mm	
10982	6.5	4,9	0,60 – 0,30	3,5*	≥ 115	C45, C45 hardened, 42 CrMo4	3,4 – 3,65	Steel, cast iron, PA, PU.
73106	8.1	6,2	0,60 – 0,30	3,5*	≥ 120	C45, C45 hardened, 42 CrMo4	4,3	Steel, cast iron, PA, PU.
78991	10	8,0	0,65 – 0,30	3,5*	≥ 200	C45, C45 hardened, 42 CrMo4	5,3	Steel, cast iron, PA, PU.

Tolerances according to ISO 2768-1 class m (middle). The CTP® rope is only certified for usage on traction and deflector sheaves that meet the requirements outlined above.



What is BRUbelt?

Whether for material handling equipment, elevators or conveyors – the BRUbelt is defined by maximum dynamic strength and is available in customized designs.

BRUbelt is the combination of high strength steel strands and high tech polymers that allows the creation of the innovative drive systems in the smallest possible space compared to conventional steel cables.

BRUbelt offers higher load-bearing capacity with a reduced metallic cross-section.

BRUbelts cover a very wide range of different applications. As an alternative to chains and wire rope hoist systems, they offer the user a maintenance-free, cost and space saving solution for the respective area of application.

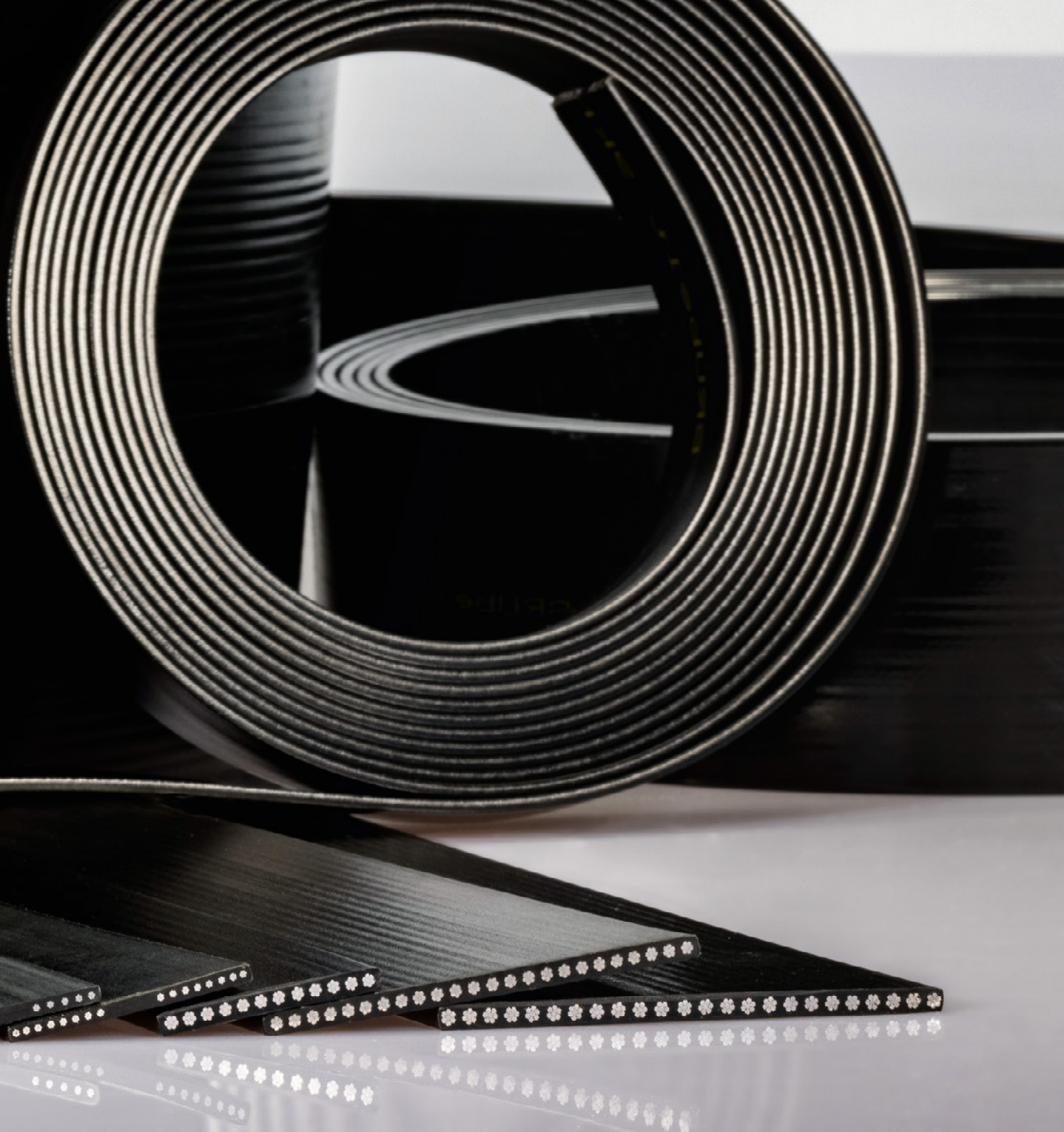

BRUbelt®

High-tensile galvanized steel cords
Abrasion-resistant
Thermoplastic dual-layer polymer jacket

 For smallest possible space and maximum dynamic strength.

 For higher load-bearing capacity with a reduced metallic cross-section

Tension member
 High-tensile galvanized steel cords

Inner layer
 Flexible and robust contact surface between outer layer and steel cord

Outer layer
 Non-abrasive

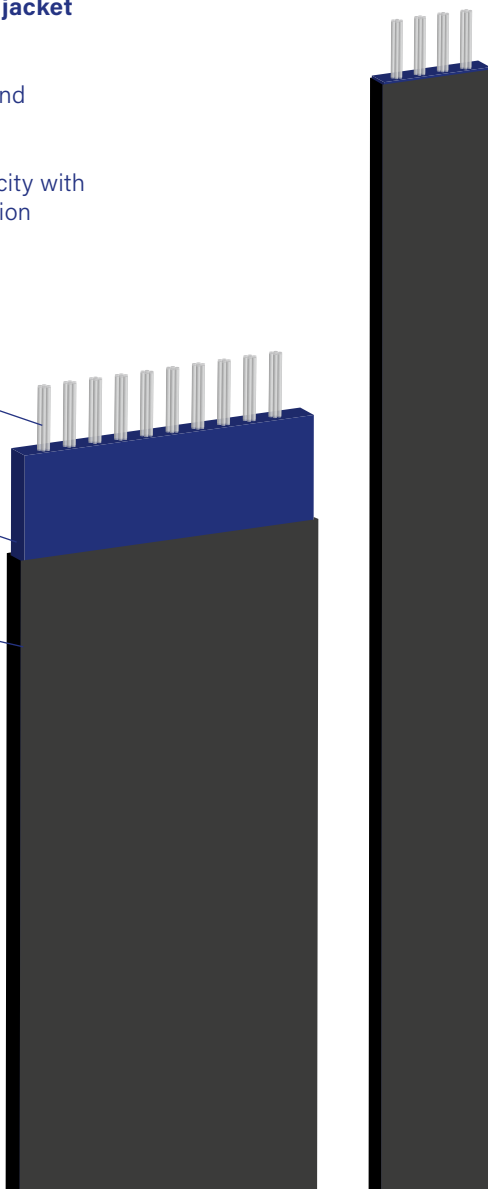

Product name	Breaking load min.	Cross-section	Numer of steel cords	Belt weight
	kN	mm x mm		g/m
BRUbelt 3.6kN	3,6	8 x 2.3	4	30
BRUbelt 7.5kN	7,5	16 x 2.3	8	60
BRUbelt 9kN	9	25 x 2.3	10	90
BRUbelt 15kN	15	33 x 2.3	16	125
BRUbelt 40kN	40	25 x 3.4	8	200
BRUbelt 50kN	50	31 x 3.4	10	250
BRUbelt 70kN	70	44 x 3.4	14	350
BRUbelt 109kN	109	70 x 3.3	24	549
BRUbelt 126kN	126	100 x 3.0	42	691
BRUbelt 218kN	218	150 x 3.3	48	1136

Advantages of the BRUbelt design

- Increased flexibility and traction
- Lower belt elongation under load
- High running quality (low vibration and noise)
- High resistance to external influences (e.g. weathering, abrasion, UV radiation)
- High tensile strength
- Extreme bending and flexural fatigue strength
- Smaller pulley and idler diameters
- High wear resistance
- Halogen and silicone free



BRUbelt flat belts save space

The high flexibility of BRUbelt flat belts in combination with their flat shape allow smaller sizes of the entire installation. Both the pulleys as well as the machines and the traction sheaves can be significantly smaller.

Also, depending on the design, a single small deflection pulley is sufficient.

This advantages enables up to 50% space savings and lower total cost of owner ship. The advantages allow a higher lifting height and thus additional available sotarge capacity or perfectly exploits a low hall height in confined spaces.

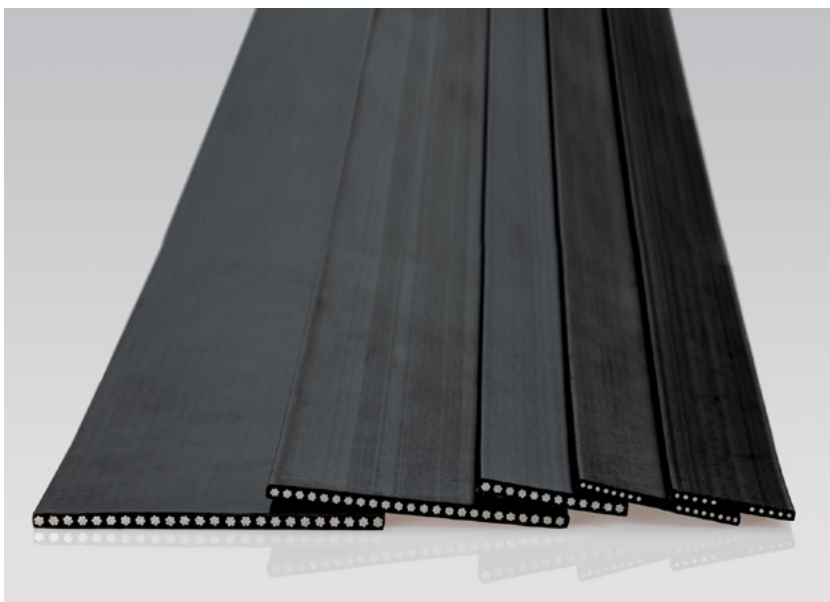

The right scope of application

Whether in the warehouse or the production hall – the flat belts can be used in their standard temperature range from -20°C to $+60^{\circ}\text{C}$ and behave in a non-condensing manner up to a relative humidity of up to 80%. However, the exact limits of use depend on the particular load case. Higher or lower temperature ranges can be accommodated in customer-specific designs.



Passenger Elevator Application



Lift table



Monorail systems



High-speed door

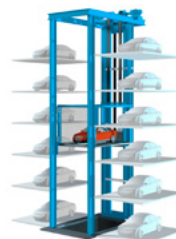

Parking systems



Vertical conveyors

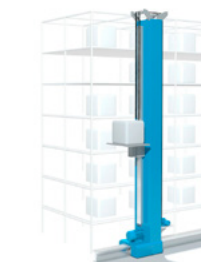

Storage and retrieval systems

BRUbelt end fasteners

With the Brubelt end connector there is no reduction of the minimum breaking load. In addition, customized end fasteners are created upon request.

The flat belts made of steel cords sheathed with thermoplastic polyurethane do not require lubrication, but run grease-free on the pulleys, which significantly reduces maintenance costs.

Compared to wire ropes, BRUbelt flat belts cause considerably less wear on belts, idler pulleys and drive sheaves, which also has a positive effect on maintenance costs.

The belt itself has three times the service life of classic steel ropes. With a wrap drive, the drive motor can be mounted close to the ground and is therefore easily accessible. The BRUbelt is also used as a traction drive, thanks to the frictional properties of the coating, the BRUbelt can be used with the smallest possible drive sheaves.

Terminations

- BRUbelt end fittings, no reduction of breaking load, ready for installation
- clamping plates
- customized designs on demand

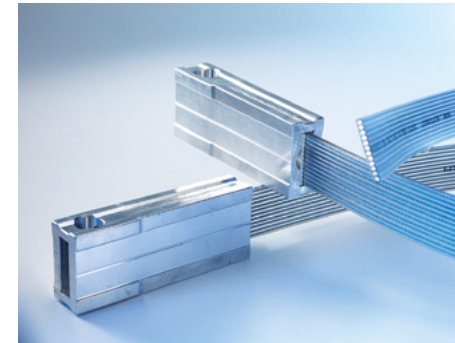

BRUbelt end fittings



Winding drive



Winding drive Traction drive

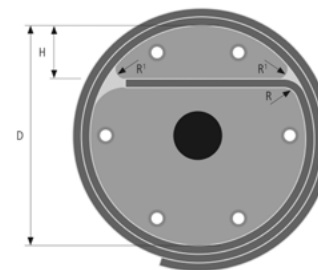

Winding pulley

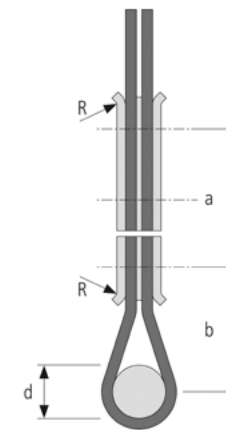

Clamping plates

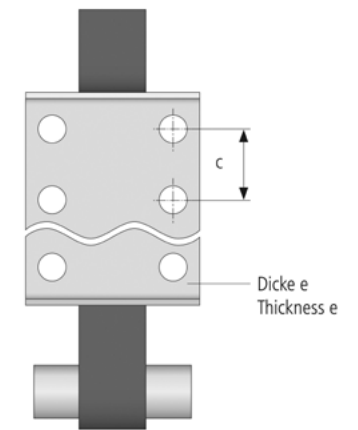

HRS

Full Steel Core Rope Parallel Lay (PWRC) 9 Strands



For highest demands on breaking force, elongation and number of trips



Recommended for round grooves with an undercut angle of $\leq 85^\circ$

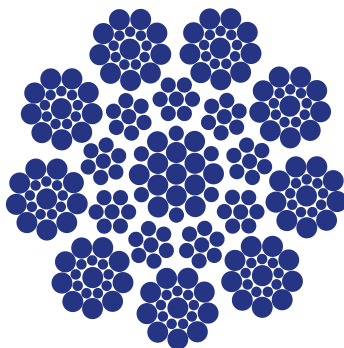

Elastic elongation	Permanent elongation	Lifting height*
0.070%	0.090%	≤ 425 m ≤ 1400 ft

item number	rope \varnothing		breaking load min.		weight		construction
	mm	in	kN	lbs	kg/100m	lb/ft	
10699	8.0	5/16	42,7	9599	26.84	0,1804	9x19S-PWRC 1570 U sZ (RRL)
10702	9.0	-	56,3	12657	35.00	0,2352	9x19S-PWRC 1570 U sZ (RRL)
10705	10.0	-	68,0	15287	42.81	0,2877	9x19S-PWRC 1570 U sZ (RRL)
10708	11.0	7/16	83,4	18749	52.52	0,3529	9x19S-PWRC 1570 U sZ (RRL)
73040	12.0	-	96,8	21762	60.90	0,4092	9x21F-PWRC 1570 U sZ (RRL)
10163	12.7	1/2	111,1	24752	69.79	0,4690	9x21F-PWRC 1570 U sZ (RRL)
10648	13.0	-	114,1	25651	71.81	0,4826	9x21F-PWRC 1570 U sZ (RRL)
10643	15.5	-	165,8	37273	104.40	0,7016	9x25F-PWRC 1570 U sZ (RRL)
78712	16.0	5/8	174,9	39319	110.12	0,7400	9x25F-PWRC 1570 U sZ (RRL)
10646	19.0	3/4	245,7	55236	154.64	1,0392	9x25F-PWRC 1570 U sZ (RRL)
10647	22.0	7/8	334,4	75180	210.50	1,4145	9x25F-PWRC 1570 U sZ (RRL)

Further nominal strengths and/or diameters (including imperial dimensions) on request. Rope diameter-tolerances according to EN12385-5/ISO 4344.

SCX9

Full Steel Core Rope Separate Lay (IWRC) 9 Strands



For highest demands on breaking force, elongation and number of trips, also under difficult installation conditions



Recommended for all groove shapes

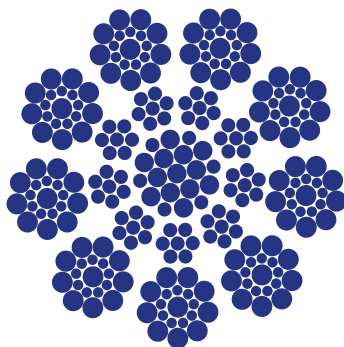

Elastic elongation	Permanent elongation	Lifting height*
0,083%	0,100%	≤ 325 m ≤ 1000 ft

item number	rope \varnothing		breaking load min.		weight		construction
	mm	in	kN	lbs	kg/100m	lb/ft	
11666	8.0	5/16	41,9	9420	26,29	0,1767	9x19S-IWRC 1570 U sZ (RRL)
73321	9.5	3/8	59,8	13452	37,56	0,2520	9x19S-IWRC 1570 U sZ (RRL)
11668	10.0	-	66,6	14972	41,79	0,2808	9x19S-IWRC 1570 U sZ (RRL)
11669	11.0	7/16	80,9	18187	50,77	0,3412	9x19S-IWRC 1570 U sZ (RRL)
11670	12.0	-	96,2	21626	60,38	0,4058	9x21F-IWRC 1570 U sZ (RRL)
73107	12.7	1/2	108,3	24347	67,99	0,4569	9x21F-IWRC 1570 U sZ (RRL)
11671	13.0	-	111,9	25156	70,26	0,4721	9x21F-IWRC 1570 U sZ (RRL)
11674	16.0	5/8	173,2	38937	108,79	0,7311	9x25F-IWRC 1570 U sZ (RRL)
11675	19.0	3/4	243,3	54696	152,81	1,0269	9x25F-IWRC 1570 U sZ (RRL)

Further nominal strengths and/or diameters (including imperial dimensions) on request. Rope diameter-tolerances according to EN12385-5/ISO 4344.

TSR

**Full Steel Core Rope
Separate Lay (IWRC)
6 Strands
Zinc-Plated**



For high demands on small traction sheaves



Suitable for conical grooves of $\geq 45^\circ$
Recommended for conical grooves and undercut round grooves

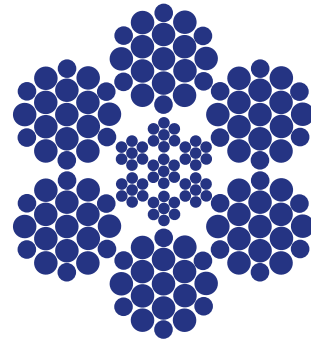

Elastic elongation	Permanent elongation	Lifting height*
0,102%	0,120%	≤ 75 m ≤ 250 ft

item number	rope ø		breaking load min.		weight		construction
	mm	in	kN	lbs	kg/100m	lb/ft	
64496	6.7	-	31.3	7037,00	20.00	0,134	6x19W-IWRC 1960 B sZ (RRL)

Further nominal strengths and/or diameters (including imperial dimensions) on request. Rope diameter-tolerances according to EN12385-5/ISO 4344.

DP9

Mixed Core Rope Parallel Lay (PWRC) 9 Strands



For high demands on breaking force, elongation and number of trips



Recommended for all groove shapes

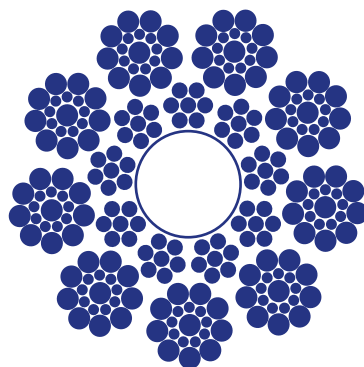

Elastic elongation	Permanent elongation	Lifting height*
0,091%	0,200%	≤ 250 m ≤ 800 ft

item number	rope ø		breaking load min.		weight		construction
	mm	in	kN	lbs	kg/100m	lb/ft	
10681	8.0	5/16	36,7	8251	25,0	0,1680	9x19S-PWRC 1570 U sZ (RRL)
10684	9.0	-	48,5	10903	33,0	0,2218	9x19S-PWRC 1570 U sZ (RRL)
10687	10.0	-	58,6	13174	40,0	0,2688	9x19S-PWRC 1570 U sZ (RRL)
10690	11.0	7/16	71,9	16164	49,2	0,3306	9x19S-PWRC 1570 U sZ (RRL)
10164	12.7	1/2	95,6	21492	64,9	0,4359	9x21F-PWRC 1370/1770 U sZ (RRL)
10696	13.0	-	98,1	22054	66,0	0,4435	9x21F-PWRC 1570 U sZ (RRL)
78730	15.5	-	144,7	32530	98,9	0,6648	9x25F-PWRC 1570 U sZ (RRL)
78733	16.0	5/8	150,9	33924	103,1	0,6928	9x25F-PWRC 1570 U sZ (RRL)
78734	16.0	5/8	148,1	33294	103,1	0,6928	9x25F-PWRC 1370/1770 U sZ (RRL)

Further nominal strengths and/or diameters (including imperial dimensions) on request. Rope diameter-tolerances according to EN12385-5/ISO 4344.

MCX9

Mixed Core Rope Separate Lay (IWRC) 9 Strands



For high demands on breaking force, elongation and number of trips. Also under difficult installation conditions



Recommended for all groove shapes

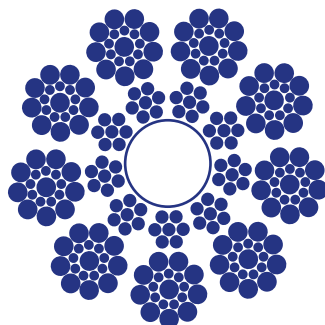

Elastic elongation	Permanent elongation	Lifting height*
0,093%	0,200%	≤ 200 m ≤ 650 ft

item number	rope ø		breaking load min.		weight		construction
	mm	in	kN	lbs	kg/100m	lb/ft	
11680	8.0	5/16	35,8	8048	22,79	0,153	9x19S-IWRC 1570 U sZ (RRL)
73467	9.5	3/8	51,2	11526	34,15	0,229	9x19S-IWRC 1570 U sZ (RRL)
11682	10.0	-	57,2	12859	36,35	0,244	9x19S-IWRC 1570 U sZ (RRL)
11683	11,0	-	69,0	15516	43,92	0,295	9x19S-IWRC 1570 U sZ (RRL)
11693	12.0	-	82,4	18524	52,41	0,352	9x21F-IWRC 1570 U sZ (RRL)
11684	12.7	1/2	92,0	20682	58,54	0,393	9x21F-IWRC 1570 U sZ (RRL)
11685	13.0	-	96,0	21582	61,05	0,410	9x21F-IWRC 1570 U sZ (RRL)
11688	16.0	5/8	147,0	33047	93,61	0,629	9x25F-IWRC 1570 U sZ (RRL)
11689	19,0	-	206,9	46513	131,76	0,885	9x25F-IWRC 1570 U sZ (RRL)

Further nominal strengths and/or diameters (including imperial dimensions) on request. Rope diameter-tolerances according to EN12385-5/ISO 4344.

8X19

**Fiber Core Rope
NFC (Sisal)
8 Strands**



For high demands on elongation also under difficult installation conditions



Recommended for all groove shapes

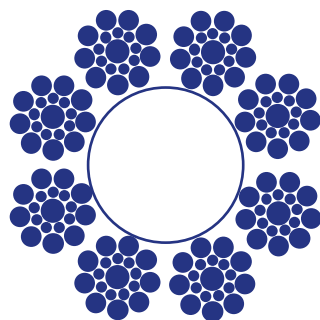

Elastic elongation	Permanent elongation	Lifting height*
0,101%	0,290%	≤ 75 m ≤ 250 ft

item number	rope ø		breaking load min.		weight		construction
	mm	in	kN	lbs	kg/100m	lb/ft	
63999	8.0	5/16	30,5	6857	21,70	0,1458	8x19S-NFC 1370/1770 U sZ (RRL)
78748	9.0	-	38,2	8588	27,00	0,1814	8x19S-NFC 1370/1770 U sZ (RRL)
63980	9.5	3/8	42,5	9554	30,30	0,2036	8x19S-NFC 1370/1770 U sZ (RRL)
78677	9.5	3/8	50,3	11308	30,30	0,2036	8x19S-NFC 1770 U zZ (RLL)
60544	10.0	-	47,2	10611	33,60	0,2258	8x19S-NFC 1370/1770 U sZ (RRL)
63996	11.0	7/16	58,6	13178	41,60	0,2796	8x19S-NFC 1370/1770 U sZ (RRL)
62928	12.0	-	71,0	15968	50,60	0,3400	8x19S-NFC 1370/1770 U sZ (RRL)
61618	12.7	1/2	79,4	17850	54,00	0,3629	8x19S-NFC 1570 U sZ (RRL)
63981	12.7	1/2	75,9	17063	54,00	0,3629	8x19S-NFC 1370/1770 U sZ (RRL)
78680	12.7	1/2	89,5	20120	54,00	0,3629	8x19S-NFC 1770 U sZ (RRL)
61577	13.0	-	81,9	18412	58,20	0,3911	8x19S-NFC 1370/1770 U sZ (RRL)
10675	15.5	-	115,2	25898	81,60	0,5484	8x19S-NFC 1370/1770 U sZ (RRL)
63989	15.88	5/8	119,6	26886	85,30	0,5730	8x19S-NFC 1370/1770 U sZ (RRL)
63990	15.88	5/8	125,4	28189	85,30	0,5730	8x19S-NFC 1570 U sZ (RRL)
29361	16.0	-	128,2	28821	87,16	0,5857	8x19S-NFC 1570 U sZ (RRL)
63982	16.0	-	122,3	27494	87,16	0,5857	8x19S-NFC 1370/1770 U sZ (RRL)
77820	16.0	-	144,4	32463	87,16	0,5857	8x19S-NFC 1770 U sZ (RRL)
73101	18.0	-	158,7	35677	113,16	0,7604	8x19S-NFC 1370/1770 U sZ (RRL)
77507	19.0	-	172,1	38689	122,80	0,8252	8x19S-NFC 1370/1770 U sZ (RRL)

Further nominal strengths and/or diameters (including imperial dimensions) on request. Rope diameter-tolerances according to EN12385-5/ISO 4344.

6X19

Wire Rope with Polypropylene Core
6 Strands
Seale



For high demands on elongation and corrosion protection with special rope lubrication

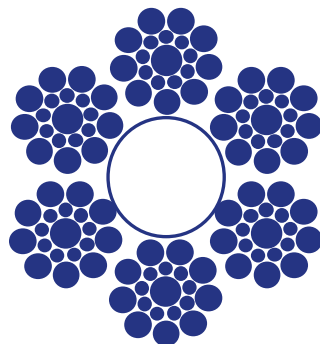

item number	rope ø		breaking load min.		weight		construction
	mm	in	kN	lbs	kg/100m	lb/ft	
29463	6.0	-	24,40	5485	12,30	0,083	6x19S-SFC 1960 B sZ (RRL)
03901	6.5	-	28,20	6340	14,36	0,096	6x19S-SFC 1960 B sZ (RRL)

Further nominal strengths and/or diameters (including imperial dimensions) on request. Rope diameter-tolerances according to EN12385-5/ISO 4344.

8X19

Wire Rope with Polypropylene Core
8 Strands
Seale



For high demands on elongation and corrosion protection with special rope lubrication

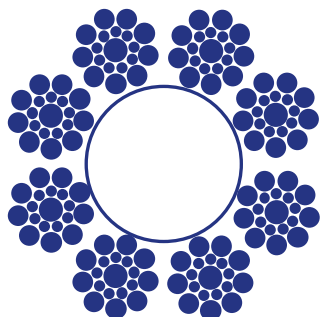

item number	rope ø		breaking load min.		weight		construction
	mm	in	kN	lbs	kg/100m	lb/ft	
61540	8.0	5/16	35,5	7981	20,97	0,1409	8x19S-SFC 1770 B sZ (RRL)
77513	9.5	3/8	50,3	11308	30,30	0,2036	8x19S-SFC 1770 B sZ (RRL)
10884	9.5	3/8	42,5	9558	30,30	0,2040	8x19S-SFC 1370/1770 U sZ (RRL)
73003	12.7	1/2	75,9	17064	53,96	0,3630	8x19S-SFC 1370/1770 U sZ (RRL)

Further nominal strengths and/or diameters (including imperial dimensions) on request. Rope diameter-tolerances according to EN12385-5/ISO 4344.



Rope Length is maintained due to the environmentally stable core. No lube throw-off keeps equipment clean

8X19

Wire Rope with Polypropylene Core
8 Strands
Seale

☞ Rope Length is maintained due to the environmentally stable core. No lube throw-off keeps equipment clean

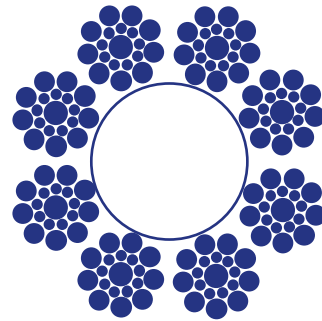

item number	rope ø		breaking load min.		weight		construction
	mm	in	kN	lbs	kg/100m	lb/ft	
77870	16.0	5/8	122,30	27494	87,16	0,5857	8x19S-SFC 1370/1770 U sZ (RRL)

Further nominal strengths and/or diameters (including imperial dimensions) on request. Rope diameter-tolerances according to EN12385-5/ISO 4344.

8X25

Wire Rope with Polypropylene Core
8 Strands
Filler

☞ Compensation ropes are used to balance the weight of hoist ropes and travelling cables in an elevator

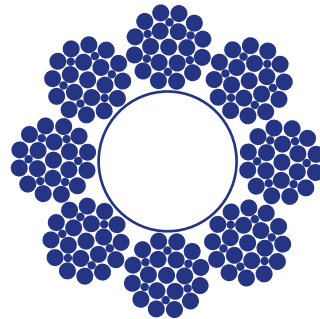

item number	rope ø		breaking load min.		weight		construction
	mm	in	kN	lbs	kg/100m	lb/ft	
73330	16.0	5/8	126,20	28371	88,77	0,5965	8x25F SFC 1370/1770 U sZ (RRL)
73044	19.0	3/4	178,40	40106	126,26	0,8485	8x25F SFC 1370/1770 U sZ (RRL)

Further nominal strengths and/or diameters (including imperial dimensions) on request. Rope diameter-tolerances according to EN12385-5/ISO 4344.





Our Accessories



APAG

Threaded Swaged Sockets [EN 13411-8]

Product Data

- APAG-end connections are TÜV tested and approved according to TRA / EN81.
- APAG-end connections transmits 80 % of minimal breaking load of traction rope

Advantages

- simple, fast and safe end terminations
- shortened installation time, since no mounting of end connections by customers
- no special tools required
- the compact type enables a very tight arrangement of ropes and parallel running ropes
- simple securing against rotation
- check hole for rope end position
- quiet operation because there are no individual parts

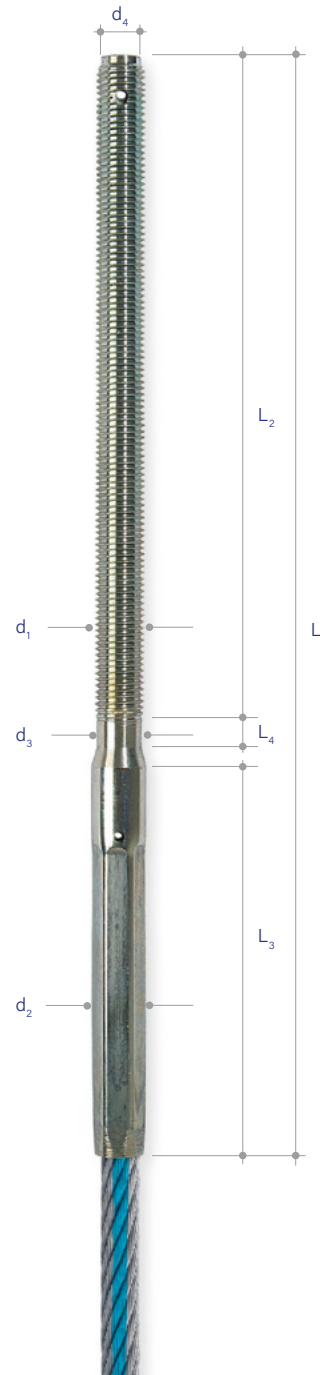

item number	rope ø	d ₁	d ₂	d ₃	d ₄	L ₁	L ₂	L ₃	L ₄
	mm	dimensions in mm							
10112	6.0	M 10	13	9.0	7	240	150	66.0	16.6
10113	6.5	M 10	13	9.0	7	240	150	71.5	11.1
77743	6.7	M 10	13	9.0	7	240	150	73.7	8.9
10114	7.0	M 12	18	10.9	9	280	180	77.0	9.7
10081	8.0	M 12	18	10.9	9	280	170	88.0	8.7
10082	8.0	M 14	18	12.7	11	280	170	88.0	12.1
10083	8.0	M 14	18	12.7	11	400	200	88.0	12.1
10084	9.0	M 14	18	12.7	11	290	170	99.0	11.1
10085	9.0	M 14	18	12.7	11	400	200	99.0	91.1
10086	9.0	M 16	18	14.7	13	340	220	99.0	14.8
10087	10.0	M 16	18	14.7	13	300	170	110.0	14.0
10088	10.0	M 16	18	14.7	13	400	250	110.0	34.0
10089	11.0	M 14	18	12.7	11	310	170	121.0	9.0
10090	11.0	M 14	18	12.7	11	420	200	121.0	89.0
10091	11.0	M 16	18	14.7	13	350	210	121.0	13.0
10092	11.0	M 16	18	14.7	13	420	280	121.0	13.0
10093	12.0	M 16	22	14.7	13	350	190	132.0	14.0
10094	12.0	M 20	22	18.4	16	400	250	132.0	11.0
10095	13.0	M 16	22	14.7	13	340	170	143.0	13.0
10096	13.0	M 16	22	14.7	13	420	250	143.0	13.0
10097	13.0	M 16	22	14.7	13	480	310	143.0	13.0
10098	13.0	M 16	22	14.7	13	540	370	143.0	13.0
10099	13.0	M 20	22	18.4	16	420	250	143.0	20.0
10100	14.0	M 20	25	18.4	16	420	250	154.0	4.0
10101	15.0	M 20	25	18.4	16	450	250	165.0	23.0
10103	15.5	M 20	27	18.4	16	450	250	170.5	13.0
10105	16.0	M 24	27	22.1	19	480	280	176.0	15.0

Other sizes available upon request.

APAG (CTP®)

Threaded Swaged Sockets

Product Data

- APAG-end connections are TÜV tested and approved according to EN81.
- APAG-end connections transmits 80% of minimal breaking load of traction rope

Advantages

- simple, fast and safe end terminations
- shortened installation time, since no mounting of end connections by customers
- no special tools required
- the compact type enables a very tight arrangement of ropes and parallel running ropes
- simple securing against rotation
- check hole for rope end position
- quiet operation because there are no individual parts

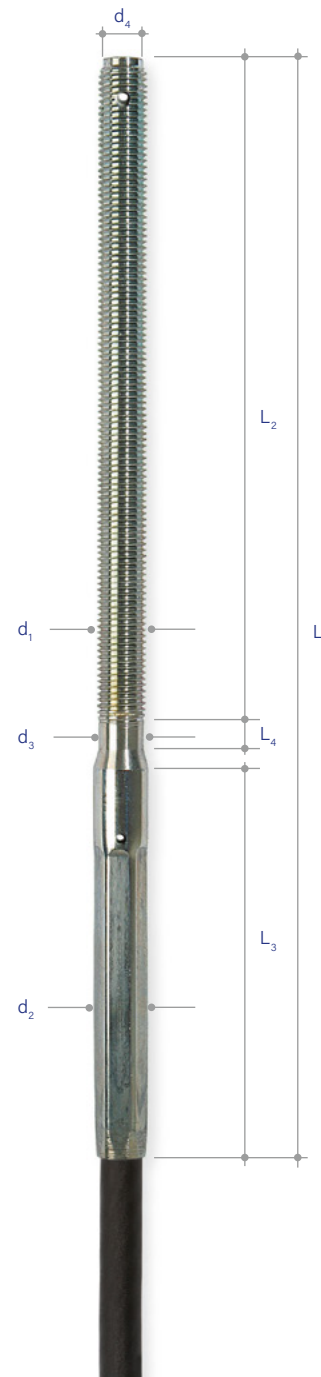

For use with CTP® 6.5 mm

item number	d_1	d_2	d_3	d_4	L_1	L_2	L_3	L_4
dimensions in mm								
10209	M 10	13	9	7	240	150	66.0	16.6

For use with CTP® 8.1 mm

item number	d_1	d_2	d_3	d_4	L_1	L_2	L_3	L_4
dimensions in mm								
10113	M 10	13	9	7	240	150	71.5	11.1

Eyelet bolt with Swaged Thimble

Product Data

- eyelet bolt steel St 37, zinc-plated

Advantages

- simple, fast and safe end terminations
- no special tools required
- simple securing against twisting

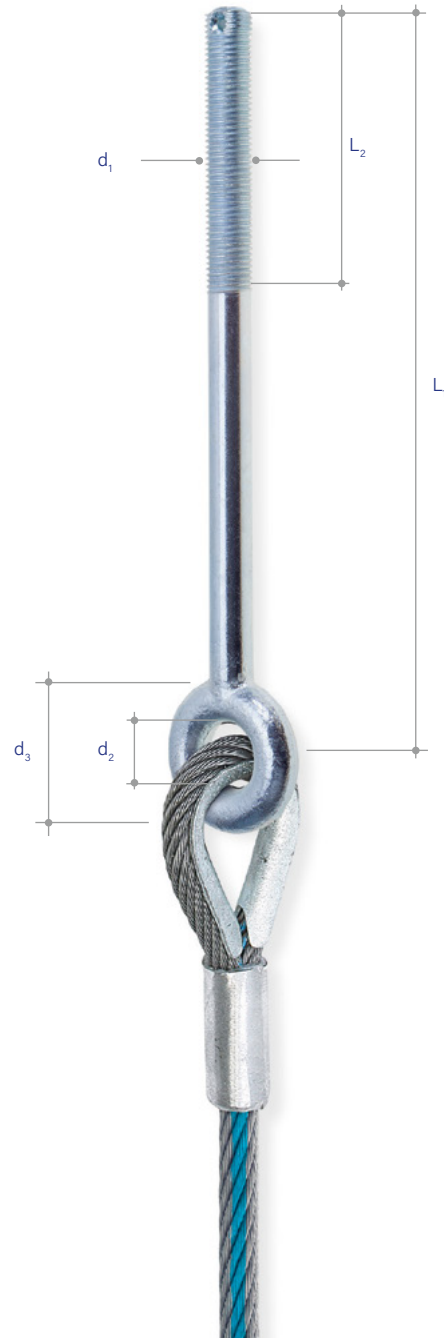

item number	rope ø	d ₁	d ₂	d ₃	L ₁	L ₂	breaking load
	mm	dimensions in mm				kN	
64250	6.0	M 12	26.0	50.0	260	60	33.7
64251	6.0	M 12	26.0	50.0	500	150	33.7
64252	6.5	M 12	26.0	50.0	260	60	33.7
64253	6.5	M 12	26.0	50.0	500	150	33.7
64254	8.0	M 12	26.0	50.0	260	60	33.7
64255	8.0	M 12	26.0	50.0	500	150	33.7
64256	9.0	M 16	22.0	51.4	260	120	62.8
64257	9.0	M 16	22.0	51.4	450	200	62.8
64258	10.0	M 16	22.0	51.4	260	120	62.8
64259	10.0	M 16	22.0	51.4	450	200	62.8
64260	11.0	M 16	22.0	51.4	260	120	62.8
64261	11.0	M 16	22.0	51.4	450	200	62.8
64262	12.0	M 20	27.7	67.6	290	120	98.0
64263	12.0	M 20	27.7	67.6	450	200	98.0
64264	12.0	M 20	27.7	67.6	600	200	98.0
64265	12.0	M 20	27.7	67.6	800	400	98.0
64266	13.0	M 20	27.7	67.6	290	120	98.0
64267	13.0	M 20	27.7	67.6	450	200	98.0
64268	13.0	M 20	27.7	67.6	600	200	98.0
64269	13.0	M 20	27.7	67.6	800	400	98.0
64270	15.5	M 24	27.0	65.0	400	220	141.0
64271	15.5	M 24	27.0	65.0	600	100	141.0
64272	16.0	M 24	27.0	65.0	400	220	141.0
64273	16.0	M 24	27.0	65.0	600	100	141.0

Other sizes available upon request.

Door closing rope sets

TSS - Rope Set

- 1 FLEX door closing rope, 3500 mm length, with one-sided pressed APAG - external thread to adjust the correct rope tension
- 1 clamping ring to fasten a rope end at a fixed point
- 1 rope clamp and 1 thimble to mount the loose rope end

One packaging unit contains 5 rope sets each.

SMZ - Rope Set

- 1 thread for easy installation DO-IT-LINE to adjust the correct rope tension
- 1 clamping ring to fasten a rope end at a fixed point
- 1 rope clamp and thimble to mount a loose rope end

One packaging unit contains 5 rope sets each.

The SMZ - rope set does not contain a door closing rope. This can be ordered separately.

Advantages

- fast and simple installation
- suitable for most elevator door-closing systems
- reduces downtimes
- complete set – all parts are included
- not much warehousing required

TSS



item number	rope ø
	mm
77720	3.0
77721	4.0

SMZ



item number	rope ø
	mm
77744	3.0
77745	4.0



Wedge Socket **Asymmetrical** [EN 13411-6] with Eyelet Bolt [DIN 444]

Product Data

- Cast rope lock, galvanized steel
- incl. wedge, pre-assembled safety splints
- Rope lock transfers 80% of the minimum break force of the rope
- Threaded rod, galvanized steel
- In connection with the rope lock, the threaded rod transfers 80% of the minimum break force of the elevator rope
- The assembly and operation is subject to the requirements in Annex B/C of the EN 13411-6 standard

Advantages

- can be assembled safely and simply on-site
- springs, buffers and other accessories can be mounted individually

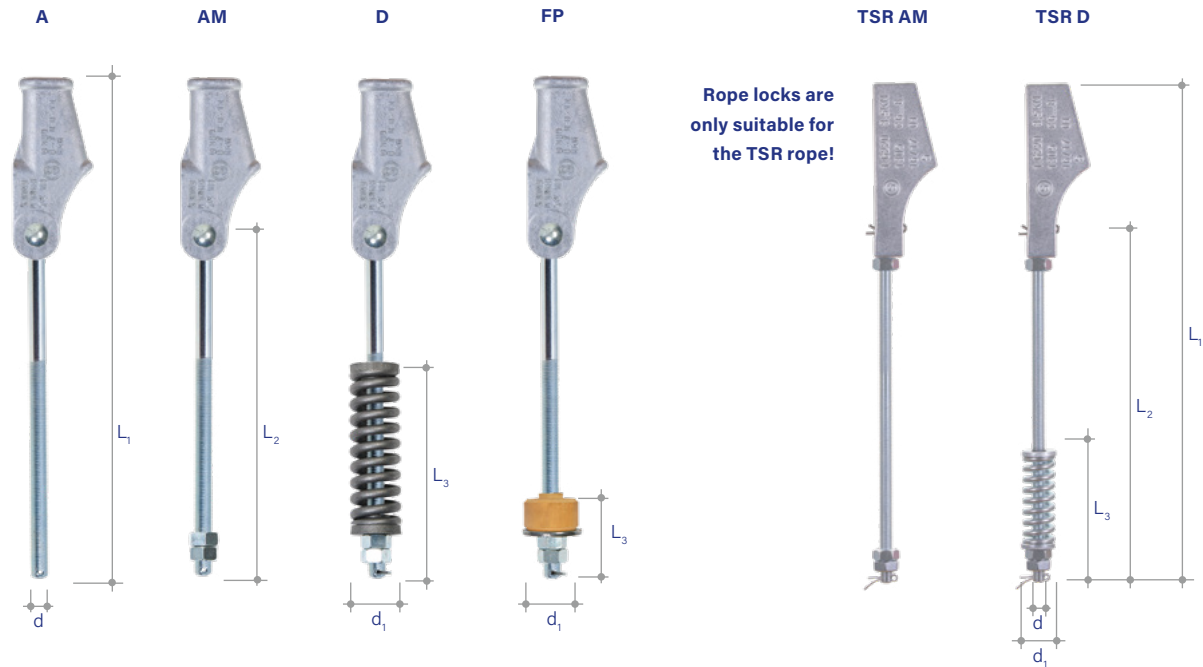

item number	rope ø	d	d ₁	L ₁	L ₂	L ₃
A	mm			dimensions in mm		
64302	6.0 - 7.0	M12		430	300	
64303	8.0	M12		430	300	
64304	9.0 - 12.0	M12		430	300	
64305	10.0 - 12.0	M16		440	300	
64306	12.0 - 14.0	M16		440	300	
64307	12.0 - 15.0	M20		590	400	

AM						
64334	6.0 - 7.0	M12		430	300	
64335	8.0	M12		430	300	
64336	9.0 - 12.0	M12		430	300	
64337	10.0 - 12.0	M16		440	300	
64338	12.0 - 14.0	M16		440	300	
64339	12.0 - 15.0	M20		590	400	

D						
64309	6.0 - 7.0	M12	44	430	300	167.0
64310	8.0	M12	44	430	300	167.0
64311	9.0 - 12.0	M12	44	430	300	167.0
64312	10.0 - 12.0	M16	44	440	300	173.0
64313	12.0 - 14.0	M16	44	440	300	173.0
64314	12.0 - 15.0	M20	50	590	400	201.5

FP						
64316	6.0 - 7.0	M12	50	430	300	51
64317	8.0	M12	50	430	300	51
64318	9.0 - 12.0	M12	50	430	300	51
64319	10.0 - 12.0	M16	57	440	300	59
64320	12.0 - 14.0	M16	57	440	300	59
64321	12.0 - 15.0	M20	68	590	400	65

TSR AM						
64294	6.5	M10		255	150	

TSR D						
64295	6.5	M10	25	255	150	91,5

Other sizes available upon request. You will find the item numbers for all combination possibilities in the price list.

Wedge Socket (CTP®) **Asymmetrical** [similar to EN 13411-6]

Product Data

- Cast rope lock, galvanized steel
- incl. wedge, pre-assembled safety splints
- Rope lock transfers 80% of the minimum break force of the rope
- Threaded rod, galvanized steel
- The assembly and operation is subject to the requirements in Annex C of the EN 13411-6 standard

Advantages

- can be assembled safely and simply on-site
- Can only be used with springs, buffers are not allowed for use with CTP ropes

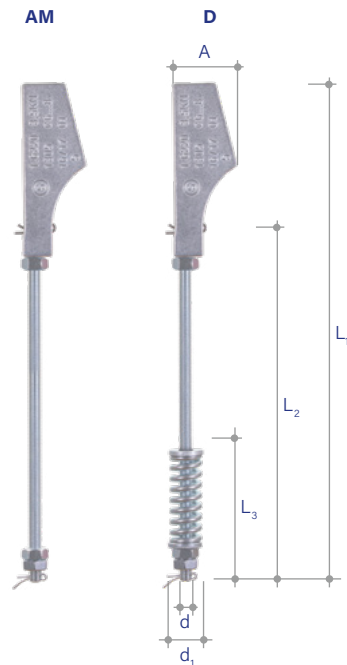

For use with CTP® 6.5 mm

item number		rope ø	d	d ₁	L ₁	L ₂	L ₃
		mm					
64294	AM	6.5	M10		255	150	
64295	D	6.5	M10	25	255	150	91,5

Other sizes available upon request. You will find the item numbers for all combination possibilities in general rope catalogue.

For use with CTP® 8.1 mm

item number		rope ø	A	d	d ₁	L ₁	L ₂	L ₃
		mm						
64296	AM	6,0 - 8,0	45	M10		355	250	
64297	D	6,0 - 8,0	45	M10	44	355	250	167,0

Other sizes available upon request. You will find the item numbers for all combination possibilities in general rope catalogue.



Door closing rope Flex

Steel Core Rope
6 Strands
Separate Lay

Special design for door drives. Due to very fine strands especially suitable for deflector sheaves. Excellent service life with regard to high bending load.

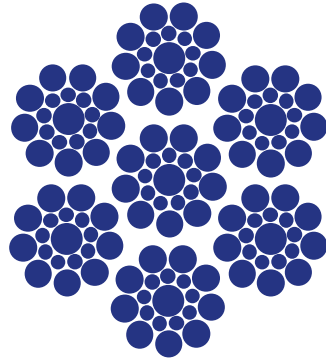

Elastic elongation	Permanent elongation
0.138 %	0.25 %

item number	rope ø	breaking load min.	weight	construction
	mm	kN	kg/100m	
04132	3.0	6.7	3.6	6x19S-WSC 1960 B sZ (RRL)
03895	4.0	11.0	6.0	6x19S-WSC 1960 B sZ (RRL)
03899	5.0	16.0	8.7	6x19S-WSC 1960 B sZ (RRL)

Rope Clamp

Rope Clamp

- zinc coated
- for mounting and operation the explanations of the norm EN 13411-5 are valid

Advantages

- can be assembled safely and simply on-site



item number	rope ø*	d	L ₁	L ₂	required torque	rope clamp/loop
	mm		dimensions in mm		Nm	pcs.
49459	5.0	M5	25	12	2.0	3
01946	6.5	M6	32	14	3.5	3
01947	8.0	M8	41	18	6.0	4
01948	10.0	M8	46	20	9.0	4
01950	12.0	M10	56	24	20.0	4
78144	13.0	M12	64	27	33.0	4
78145	14.0	M12	66	28	33.0	4
01951	16.0	M14	76	32	49.0	4
01952	19.0	M14	83	36	68.0	4
01953	22.0	M16	96	40	107.0	5

* Corresponds to the maximum rope diameter. For interim sizes of the rope diameter the next-largest clamp size is to be used.

Elastomer buffers for Rope Attachment

Product Data

- polyurethane elastomer with cells
- suitable for APAG, eyelet bolt, wedge socket symmetrical and asymmetrical

Advantages

- excellent buffering properties at minimum overall height
- transverse elongation
- also applicable on the counterweight side as rope length compensation
- grease- and oil resistant

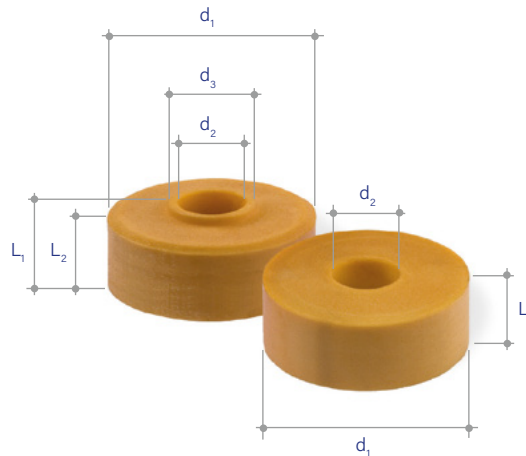

item number	for tread	d1	d2	d3	L1	L2	max. stat. weight	max. pressure force
	mm	dimensions in mm					kg	kN
77658 *	M12	50	13	22	28	33	170	6.867
77659	M12	50	13		28		170	6.867
77660 *	M16	50	17	22	28	33	170	6.867
77661	M16	50	17		28		170	6.867
77662 *	M20	65	21	27	28	33	270	11.772
77663	M20	65	21		28		270	11.772
77664 *	M24	80	25	27	28	33	420	17.658
77665	M24	80	25		28		420	17.658

* with collar. If not expressly desired differently, we supply rope attachments with a buffer always with a collar. In case of several buffers always the top one with collar.

Spring

Product Data

- steel spring, bright
- cylindrical type
- suitable for APAG, eyelet bolt, wedge socket symmetrical and asymmetrical

Advantages

- improved riding comfort

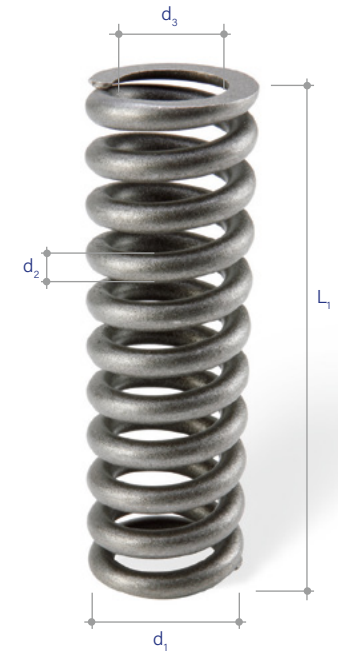

item number	for tread	d1	d2	d3	L1	spring rate	spring force
	mm	dimensions in mm				N/mm ²	kN
64468	M10	23.5	4.5	14.5	61.5	81.0	1.703
64469	M12	43.0	7.5	28.0	135.0	71.0	3.382
64470	M16	46.0	9.0	28.0	135.0	146.0	5.930
64471	M20	53.0	11.0	31.0	157.5	223.0	9.383
64472	M24	65.0	15.0	35.0	190.0	458.0	14.880
64472	M27	65.0	15.0	35.0	190.0	458.0	14.880
on request	M30	80.0	18.0	44.0	155.0	908.3	24.525
substitute for 64469 od 64470							
10822	M12	31.0	7.0	17.0	148.0	124.5	2.500
77746	M16	33.0	8.0	17.0	122.0	114.7	2.740

GDC

Grove Depth Comparator



The GDC enables you to precisely measure and compare sheave groove variations. It enables early detection of worn-out drive sheaves and may thus help to increase the service life of ropes.

Advantages

Robust design in aluminum with anodized surface. Application in seconds. Weight of only 100g. Applicable for diameters from 8-22 mm or 3/8-3/4 inch Precise finish

item number	size	version
77768	8 - 19 mm	metric
77749	3/8 - 13/16 in	imperial

RWG

Rope Wear Gauge



Within seconds, the precision gauge enables you to check whether the minimum nominal diameter of the rope is below the target. If below limit, the rope must be replaced.

Advantages

Robust design in aluminum with anodized surface. Application in seconds. Weight of only 100g. Applicable for diameters from 8-22 mm or 3/8-3/4 inch Precise finish

item number	size	unit of measurement
10909	8 - 22 mm	metric
10910	3/8 - 3/4 in	imperial

Caliper



Wide flange calipers are specialized calipers designed to measure wire rope diameters. The flanges are wide so the contact spans over more than one strand to give an accurate measurement.

item number	version
	digital
72329	DIN 862

Radius Gauge



A radius gauge allows the technician to quickly determine if the sheave groove is worn. Seat the radius gauge in the groove and direct a flashlight at the radius gauge from behind where it is seated in the groove. If light can be seen under the radius gauge, the sheave groove is worn. To get the exact depth of wear, use the GDC.

item number	Set
	pieces
11240	52

VT-LUBE

Rope Care Lubricant



This rope care lubricant was especially developed for the relubrication of elevator ropes.

Advantages

- Excellent penetration quality causes optimum friction reduction in the rope
- Excellent creep quality enables even lubricant distribution on and in the rope
- Excellent corrosion protection suitable for high rope speed; through very good adhesive quality neutral quality towards synthetic materials (no swelling of plastic parts)

item number	content
	liter
77738	5

Rope Lubrication



The Simalube Smart Lubrication device automatically releases the flow of metered field lubricant that is guaranteed compatible with the grease applied in the wire rope factory. The lube flow rate is set with an allen wrench to meter the flow of the lube over a customized period of one to 12 months.

item number	description
77750	Rope Care Lubrication Set
	Content
77751	1x SLX VT-Lube 125
77752	1x Fixation nipple
77753	1x Brush 100mm

Rope Cutters



item number	rope ø	weight	length cutters
	mm	kg	mm
07534	up to 12	1.5	500
07535	up to 16	2.3	600

Hydraulic Rope Cutters



item number	rope ø	weight	length cutters
	mm	kg	mm
77790	8-20	2.7	370

RPM

Rope Performance Measurement Device

The RPM Rope performance measurement device makes it easier for you to check the rope tension during the installation, inspection and maintenance of elevators.

Advantages

- quick, easy and precise determination of rope diameter and tension
- comparison and measurement of the rope tensions, e.g. within a rope set
- determination of the weight of cabin, counterweights, etc.
- easy documentation, query and comparison of the last 94 measuring results through storage in the device
- high precision of rope tension measurement of $\pm 5\%$ and diameter measurement of $\pm 1\%$
- versatile through battery-supplied operation (1 x 9 V battery)
- handy device: just 330 x 230 x 50 mm (12.9 x 9.1 x 2.0 in), weight only 2.6 kg (5,73 lb)

Keep the tension under control

Only the even tension within an elevator rope set can guarantee a wear- and maintenance-low operation and secure a high economic efficiency.



item number	rope ø	
	mm	in
70020	8-22	5/16 - 7/8



Packaging

When selecting the packaging, BRUGG Lifting chooses the best transport protection possible. Our ropes are protected during transport with special packaging materials against corrosion and mechanical damaging.

Whenever possible, our ropes are delivered on sturdy returnable reels and drums that can be reused.



Cross Drums

capacity according to rope diameter from 100 m (ø 16 mm) to 400 m (ø 6,5 mm)



Round Reels *

ø / width: 300-600 mm / 320-530 mm

* Non-returnable packs from cardboard / wood



Coils

up to 50 m or 30 kg



XJ-Wooden Reels ø100 x 65 cm

capacity according to rope diameter from 1000 m HRS (ø 16 mm) or 1132 kg reel weight up to 4100 m HRS (ø 8 mm) or 1118 kg reel weight



System Deliveries on Pallets

consisting of rope / end terminations / accessories / mounting material



System Deliveries in Sturdy Cardboard Box

L / W / H: 80x60x80 cm / 120x60x80 cm



A woman with glasses and a patterned jacket looks upwards with a hopeful expression. In the foreground, a person is blurred, suggesting movement. The background is a bright window with a warm, golden light. The text "Together, we're letting our imagination soar." is overlaid in white, elegant font.

Together, we're letting
our imagination soar.



Technical information





What is Rope Elongation & Rope Modulus and Why is it Important?

The stretching behavior of elevator ropes contributes significantly to reliable and comfortable elevator operation, especially with increasing heights. In order to compare different ropes and to understand how they behave under different load conditions, reference values are required that describe this behavior.

For the assessment of the stretching behavior of ropes, we mainly use three characteristic values:

- 1. the permanent elongation,**
- 2. the elastic elongation**
- 3. the rope modulus (elastic modulus)**

The elastic elongation and the rope modulus are mathematically linked and inversely correlated. I.e. a large elastic elongation means a low rope modulus.



What is Permanent Elongation?

At the beginning of the service life, there is a settling effect that occurs in all suspension ropes when they are placed under load. As the wires and strands in the rope take up load, the outer layers of the rope constrict around the core. This results in the rope stretching and thus being permanently elongated.

The permanent stretch is a measure of this initial elongation of the rope (A). This is known as the running-in phase of the rope life. The smaller the permanent stretch, the less a rope must be shortened after the running-in phase. After the running-in phase, the rope length remains almost the same and only increases slightly (B). At the end of its service life, the ropes will suffer from wire abrasion, wire breaks and material fatigue, and the rope will again begin to stretch (C).

Stretch during hoist rope life span

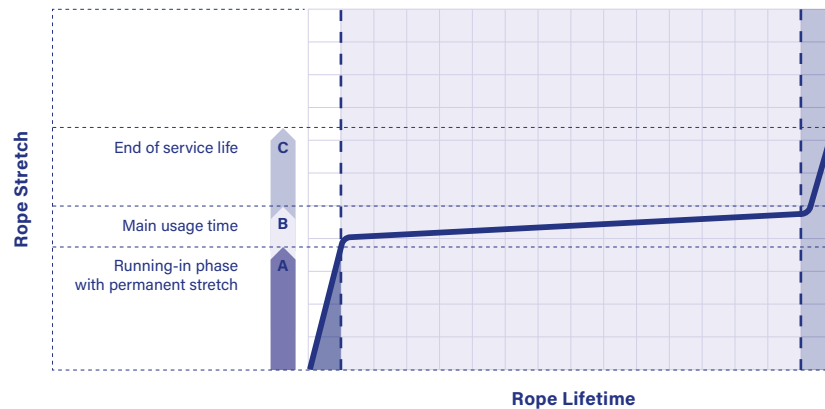

What is Elastic Elongation?

The elastic stretch provides information about how much the rope stretches as a result of the current load. For example, the elastic stretch is a measure of how much the rope stretches for each extra kg loaded into the elevator car.

The smaller the elastic stretch, the better a rope is suitable for higher travel heights. A smaller elastic stretch means that movement when people boarding is better as well as improved ride comfort. Our values for the elastic elongation are based on a load with a force of 5% of the minimum breaking load (MBL), which normally corresponds to an elevator system with a half-full elevator car.

Elastic Stretch Example

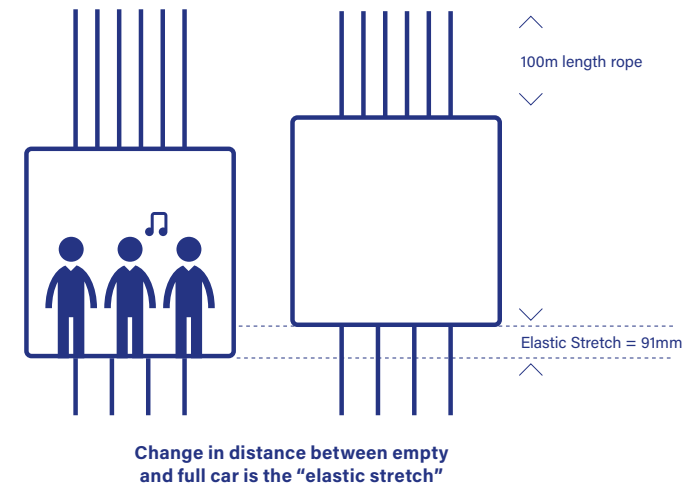

In this case the elastic elongation would be 0,091%, see formula below:

$$\frac{91 \text{ mm}}{100 \text{ m} \times 1000 \frac{\text{mm}}{\text{m}}} \times 100\% = 0,091\%$$

What is Rope Modulus?

The rope modulus is a calculated value that relates the following inputs: Metallic area (A), force (F) & stretch (ε) which enables the conversion of any load (force in N) into an elastic stretch value (in mm) and thus plays an important role in the design of an elevator. The mathematic relationship is shown below.

$$E = \frac{1}{A} * \frac{dF}{d\epsilon}$$

Because a rope is made up of many (100+) wires which move independently and interact in a non-linear way, the relationship between load and strain is not proportional. This can best be explained using a diagram.

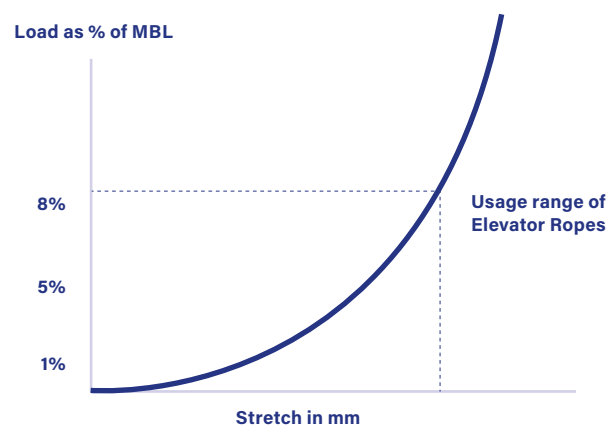

As can be seen, the curve becomes steeper as the load increases. The rope modulus can be understood simply as a conversion factor between load and strain. Since the relationship between load and strain is not proportional, this conversion factor is not always the same. For example, at 1% minimum breaking load (MBL) a small increase in force results in more stretch than at 8% MBL.

How does Brugg Lifting measure these values?

Since elevator ropes are used between 2% and 8.3% of Minimum Breaking Load, we now state the values in the application-oriented load ranges 3%, 5% and 7% of the breaking load.

This is made possible by a specially developed measuring method that simulates the rope's running-in phase. After this phase we measure all three of the characteristic values described above in just one measurement.

For this purpose, a suspension rope is subjected to 50 cycles with increased load in order to simulate the setting of the rope. During the entire test, the strain behavior is recorded using a laser strain gauge and then each of the 50 cycles is evaluated automatically. The rope modulus value at the respective load levels (3%, 5% and 7%) is calculated as the average of the last 15 cycles. The permanent elongation is captured at the last cycle.



This chart shows the typical behavior of the permanent elongation and the rope modulus during a test of a DP9 elevator rope.

Test results of a DP9 Traction Rope

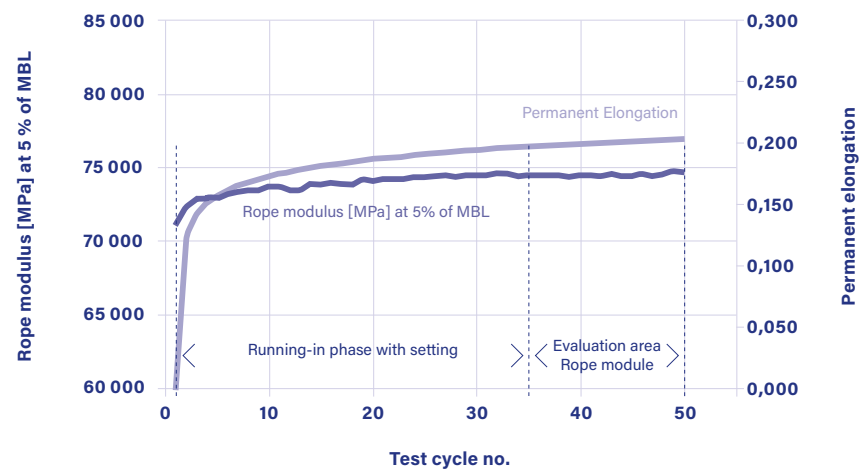

Technical specifications

Below you will find guide values for our products.

	HRS	DP9	SCX9	MCX9	8x19	TSR
Permanent Elongation [%]	0,090	0,200	0,100	0,200	0,290	0,120
Elastic Elongation with 5% MBL [%]	0,070	0,091	0,083	0,093	0,101	0,102
Rope modulus with 3% MBL [N/mm ²]	87 000	64 000	74 000	64 000	63 000	56 000
Rope modulus with 5% MBL [N/mm ²]	95 000	71 000	81 000	71 000	69 000	67 000
Rope modulus with 7% MBL [N/mm ²]	103 000	78 000	87 000	78 000	75 000	78 000

The specified values, in particular the rope module, are to be understood as general guide values for a rope type and should serve as an orientation point. The actual values of a specific rope are always dependent on the rope diameter and manufacturing-related factors. The content of this table is therefore neither a binding quality basis nor a specification of the ropes. We will be happy to help you with any questions about the technical information.



CTP® Inspection Manual

This document shall serve as practical guidance for CTP® rope inspections out in the field. It covers the official discard criteria of the CTP® rope as well as specific fields of inspection in a running elevator system which are most critical to rope life.

1. Discard criteria of the CTP® rope

BRUGG Lifting applies a simple replacement criteria that limits the use of the CTP® rope to a defined number of rides⁽¹⁾. This method of appraisal is therefore based on the level of usage.

This discard criterion forms part of all CTP® rope certifications, which have been issued by LIFTINSTITUUT. The calculation of maximum allowed trips is described under chapter "conditions" as follows:

- The defined maximum number of bending cycles is divided by the number of pulleys that are passed most often by the bended rope.

During inspection the condition of the ropes should always be checked for any abnormal wear or damage⁽²⁾. The table on page 51 shows the five typical rope issues which can occur in an elevator system and the according actions, which must be taken by the elevator maintenance company in such a case.

⁽¹⁾ Every change of direction will be counted as a trip or cycle by the lift controller.
Important: "trip" or "cycle" should NOT be confused with "starts".

⁽²⁾ The abnormal wear or damages presented below could be caused by overloading, unequal rope tension, severe shock, loading, torsional unbalance, bad rope alignment, etc. The maximum number of broken wires defined in the instructions is based on standards (UNE-EN, ISO, DIN) as well as on verification by testing samples.

2. Elevator specifications

Only with the help of specific elevator data are we able to analyze the rope regarding traction capabilities, bending fatigue performance, etc. Therefore in case of support please contact your BRUGG Lifting representative.

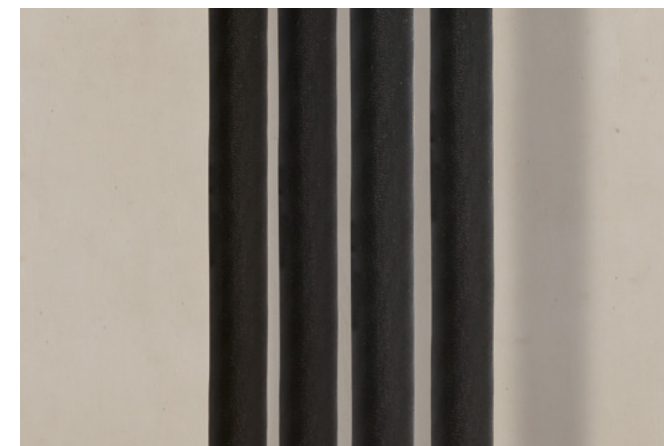

Intact ropes in elevator shaft. Note that there is no color change of coating during the entire rope life. The rope remains dark black.

3. Visual inspection

External factors that could have a negative impact on the rope should be evaluated. Before doing detailed measurements we recommend to first visually check the outside appearance of the rope. Particular attention must be paid to the rope coating:

- Broken wires piercing out of the coating material
- Irregularities regarding rope coating surface (bumps, dents, or similar)
- Scratches, tear or fractures on the rope coating
- Abrasion of the coating (TPU dust on the rope or on the sheaves)
- Dust, oil, water etc. on the rope coating
- Rope kinks

The following points should also be evaluated:

- Rope touching elevator parts or shaft
- Ropes touching each other due to electro-static charge
- Rope vibration during operation
- Insufficient alignment of traction sheave and/or diverting pulley

Whenever possible, pictures of the rope should be taken during inspection (also in the case of intact ropes). Also traction sheave, diverting pulley and end terminations should be photographed.

4. Inspection of fleet angle

The allowable fleet angle is 0.5° . If the fleet angle is too big it will induce torsion into the rope. This effect also applies to conventional ropes but is even more pronounced in the CTP® rope.

The most critical positions are when the cabin is at the top floor (maximum fleet angle between cabin and tractions sheave/deflecting pulley) and when the cabin is at the lowest floor (maximum fleet angle between counter weight and traction sheave/deflecting pulley). It is fairly difficult to directly measure the fleet angle between rope and sheave. For this reason we recommend an indirect more practical way of measuring the fleet angle (please see below).

To get a rough estimate on the fleet angle measure following points (illustrated on an elevator with 1:1 suspension):

- 1 Distance from traction sheave to end termination on lift car (when cabin is at the very top)
- 2 Distance from rope to rope at rope termination on elevator cabin. Distance from rope to rope on traction sheave (groove-to-groove distance) and on rope termination on counter weight
- 3 Distance from traction sheave to end termination on counter weight (when cabin is at the very bottom)

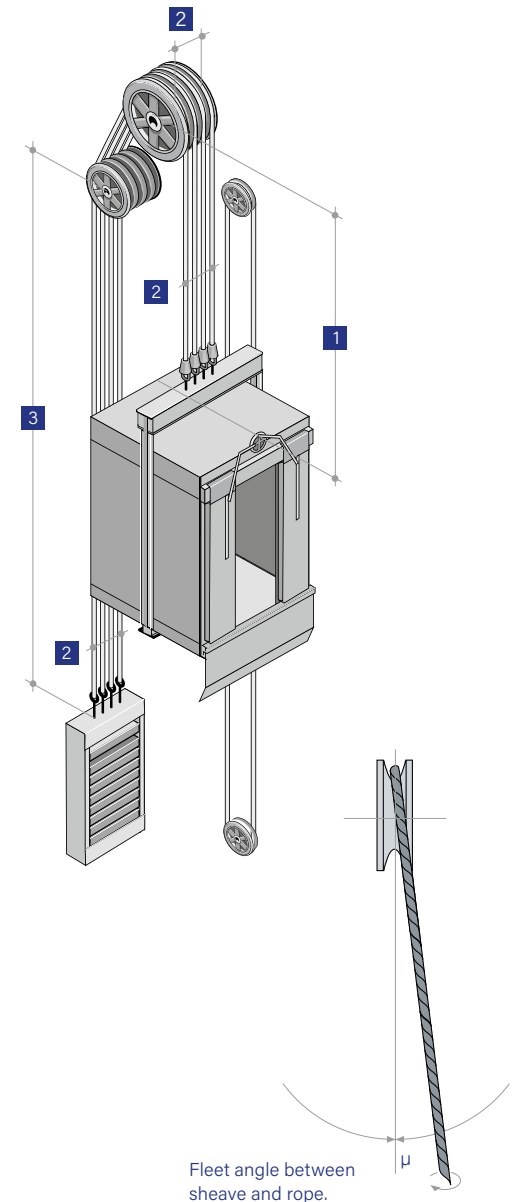

5. Inspection of groove shape (Traction sheave and diverting pulley)

Even if traction sheave and diverting pulley grooves are manufactured according to drawing, we strongly recommend to check the shape with the specially designed BRUGG groove gauge. BRUGG Lifting provides a custom made gauge which includes the 45° (30° – 45° for CTP® 6.5) opening angle as specified in our CTP® certificate.

Furthermore check the groove surface for following defects:

- Rust or abrasion of rope coating on or around sheave
- Wet surface (water, oil, etc.)

Finally, check if the bearings of the diverting pulleys still run smoothly, if possible.



BRUGG groove gauge

6. Rope tension

Even though rope tension is often measured by hand (by plucking the rope and judging by "feeling") this method is far from accurate. Comparing spring buffers with each other is more precise – to a certain extent but not all elevators are equipped with such springs. The most reliable way of measuring rope tension is by measuring the tension on the rope itself. There are various tools for measuring tension commercially available. BRUGG Lifting recommends our own specialist tool the BRUGG RPM.



Rope tension device BRUGG RPM



Safety Instructions

Most of these inspections must be performed on a running elevator (in maintenance mode)!

Never perform below listed measurements without a trained authorized elevator personnel.

Be sure to be secured at all times when standing on top of the lift car.

CTP® ropes should not be operated if oil or water is on the surface of the rope. If water or oil is on the surface of the rope and then comes into contact with the traction sheave, it will reduce traction capability and cause slippage.

General Discard Criteria

	A	B	C	D	
Problem	Plastic coating damage	Breakage of wire	Massive breaking of wires	Breakage of strand	Rope out of groove
Description	Plastic coating has worn down such that metallic wire rope core can be seen.	More than 10 wires protruding from the TPU sheath in 1 m.	More than 3 wires protruding from the plastic coating within 30 mm of the rope. Specific phenomenon located over a short run of the rope.	Specific rope breakage	Rope has fallen out from its initial groove, or jumped to the adjacent groove.
Corrective Action	Record a report to BRUGG Lifting. Replace ALL ropes.	Record a report to BRUGG Lifting. Replace ALL ropes.	Record a report to BRUGG Lifting. Stop the elevator and replace all ropes.	Record a report to BRUGG Lifting. Stop the elevator and replace all ropes.	Record a report to BRUGG Lifting. Stop the elevator and replace all ropes.
Time scale	< 2 months	< 2 months	Immediate	Immediate	Immediate

In case of abnormal rope wear or damage BRUGG Lifting suggests the maintenance or installation company to perform further inspection as described in steps 2 to 6 in order to determine possible root causes.

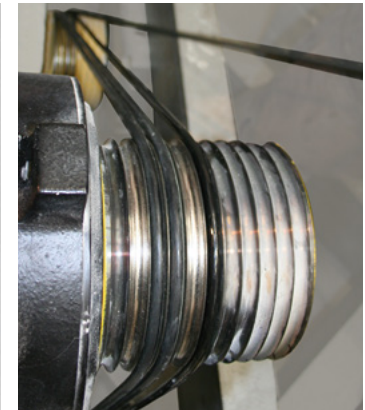

We're transforming
elevator design to
push the boundaries
of what's possible
in lifting.



Lifting doesn't
have to be boring.



**Lift yourself up
with our Brugg
playlist on Spotify!**

<https://spoti.fi/2Syv7Us>

[linkedin.com/company/brugg-lifting](https://www.linkedin.com/company/brugg-lifting)

[instagram.com/brugglifting](https://www.instagram.com/brugglifting)

[facebook.com/brugglifting](https://www.facebook.com/brugglifting)

No matter where,
we are there



Our quality products are available
from more than 20 distributing
partners around the world.
All contacts on [brugglifting.com](https://www.brugglifting.com)

Switzerland

BRUGG Lifting AG
Wydenstrasse 36
5242 Birr
Switzerland

T +41 (0) 56 464 42 42
F +41 (0) 56 464 42 84
info.lifting@brugg.com
brugglifting.com

BRUGG Lifting AG
Chemin de Forét 12
1024 Ecublens
Switzerland

T +41 (0) 21 634 20 21
F +41 (0) 21 635 09 71
vente.lifting@brugg.com
brugglifting.com

USA

BRUGG Lifting North America LLC
3411 Turkey Mountain Road NE
US-Rome, GA 30161

T +1 706 235 6315
lifting.usa@brugg.com
brugglifting.com

China

BRUGG Lifting
Plant 3, Nr. 88 Jinling East Road
Suzhou Industrial Park
Jiangsu Province, 215121
P.R. China

T +86 512 6299 0779
F +86 512 6299 0774
lifting.cn@brugg.com
brugglifting.cn



